

Features

- Protocol
 - CAN Used as a Physical Layer
 - 7 ISP CAN Identifiers
 - Relocatable ISP CAN Identifiers
 - Autobaud
- In-System Programming
 - Read/Write Flash and EEPROM Memories
 - Read Device ID
 - Full-chip Erase
 - Read/Write Configuration Bytes
 - Security Setting from ISP Command
 - Remote Application Start Command
- In-Application Programming/Self-Programming
 - Read/Write Flash and EEPROM Memories
 - Read Device ID
 - Block Erase
 - Read/Write Configuration Bytes
 - Bootloader Start

Description

This document describes the CAN bootloader functionalities as well as the CAN protocol to efficiently perform operations on the on-chip Flash (EEPROM) memories. Additional information on the T89C51CC01 product can be found in the T89C51CC01 datasheet and the T89C51CC01 Errata sheet available on the Atmel web site, www.atmel.com.

The bootloader software package (source code and binary) currently used for production is available from the Atmel web site.

Bootloader Revision	Purpose of Modifications	Date
Revisions 1.0.4 and higher	First release	02/12/2001



**CAN
Microcontrollers**

**T89C51CC01
CAN Bootloader**

Rev. 4210D-CAN-05/06



Functional Description

The T89C51CC01 Bootloader facilitates In-System Programming and In-Application Programming.

In-System Programming Capability

In-System Programming allows the user to program or reprogram a microcontroller on-chip Flash memory without removing it from the system and without the need of a pre-programmed application.

The CAN bootloader can manage a communication with a host through the CAN network. It can also access and perform requested operations on the on-chip Flash memory.

In-Application Programming or Self-Programming Capability

In-Application Programming (IAP) allows the reprogramming of a microcontroller on-chip Flash memory without removing it from the system and while the embedded application is running.

The CAN bootloader contains some Application Programming Interface routines named API routines allowing IAP by using the user's firmware.

Block Diagram

This section describes the different parts of the bootloader. Figure 1 shows the on-chip bootloader and IAP processes.

Figure 1. Bootloader Process Description

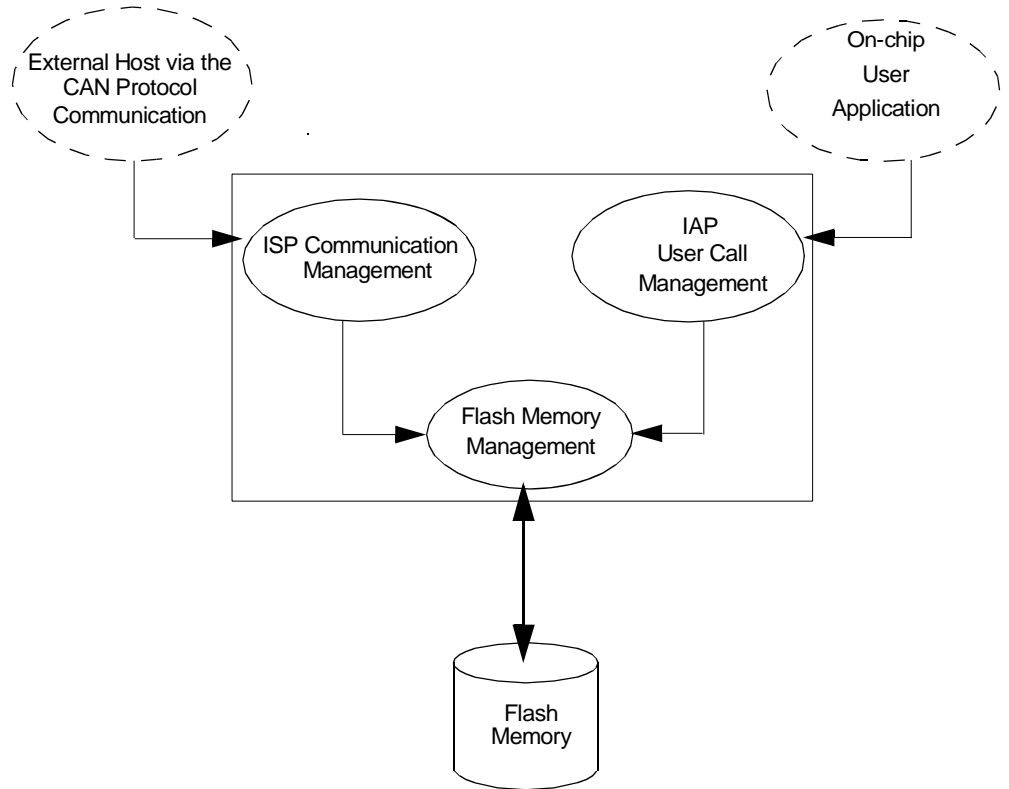

ISP Communication Management

The purpose of this process is to manage the communication and its protocol between the on-chip bootloader and an external device (host). The on-chip bootloader implements a CAN protocol (see Section “Protocol”, page 10). This process translates serial communication frames (CAN) into Flash memory accesses (read, write, erase...).

User Call Management

Several Application Program Interface (API) calls are available to the application program to selectively erase and program Flash pages. All calls are made through a common interface (API calls) included in the bootloader. The purpose of this process is to translate the application request into internal Flash Memory operations.

Flash Memory Management

This process manages low level accesses to the Flash memory (performs read and write accesses).

Bootloader Configuration

Configuration and Manufacturer Information

The following table lists Configuration and Manufacturer byte information used by the bootloader. This information can be accessed through a set of API or ISP commands.

Mnemonic	Description	Default Value
BSB	Boot Status Byte	FFh
SBV	Software Boot Vector	FCh
SSB	Software Security Byte	FFh
EB	Extra Byte	FFh
CANBT1	CAN Bit Timing 1	FFh
CANBT2	CAN Bit Timing 2	FFh
CANBT3	CAN Bit Timing 3	FFh
NNB	Node Number Byte	FFh
CRIS	CAN Relocatable Identifier Segment	00h
Manufacturer		58h
ID1: Family Code		D7h
ID2: Product Name		BBh
ID3: Product Revision		FFh

Mapping and Default Value of Hardware Security Byte

The 4 Most Significant Byte (MSB) of the Hardware Byte can be read/written by software (this area is called Fuse bits). The 4 (Least Significant Byte) LSB can only be read by software and written by hardware in parallel mode (with parallel programmer devices).

Bit Position	Mnemonic	Default Value	Description
7	X2B	U	To start in x1 mode
6	BLJB	P	To map the boot area in code area between F800h-FFFFh
5	Reserved	U	
4	Reserved	U	
3	Reserved	U	
2	LB2	P	To lock the chip (see datasheet)
1	LB1	U	
0	LB0	U	

Note: 1. U: Unprogram = 1
P: Program = 0

Security

The bootloader has Software Security Byte (SSB) to protect itself from user access or ISP access.

The Software Security Byte (SSB) protects from ISP accesses. The command 'Program Software Security Bit' can only write a higher priority level. There are three levels of security:

- Level 0: **NO_SECURITY** (FFh)
This is the default level.
From level 0, one can write level 1 or level 2.
- Level 1: **WRITE_SECURITY** (FEh)
In this level it is impossible to write in the Flash memory, BSB and SBV.
The Bootloader returns ID_ERROR message.
From level 1, one can write only level 2.
- Level 2: **RD_WR_SECURITY** (FCh)
Level 2 forbids all read and write accesses to/from the Flash memory.
The Bootloader returns ID_ERROR message.

Only a full chip erase command can reset the software security bits.

	Level 0	Level 1	Level 2
Flash/EEPROM	Any access allowed	Read only access allowed	All access not allowed
Fuse bit	Any access allowed	Read only access allowed	All access not allowed
BSB & SBV & EB	Any access allowed	Read only access allowed	All access not allowed
SSB	Any access allowed	Write level2 allowed	Read only access allowed
Manufacturer info	Read only access allowed	Read only access allowed	All access not allowed
Bootloader info	Read only access allowed	Read only access allowed	All access not allowed
Erase block	Allowed	Not allowed	Not allowed
Full chip erase	Allowed	Allowed	Allowed
Blank check	Allowed	Allowed	Allowed

Software Boot Vector

The Software Boot Vector (SBV) forces the execution of a user bootloader starting at address [SBV]00h in the application area (FM0).

The way to start this user bootloader is described in Section “Boot Process”.

Figure 2. Software Boot Vector

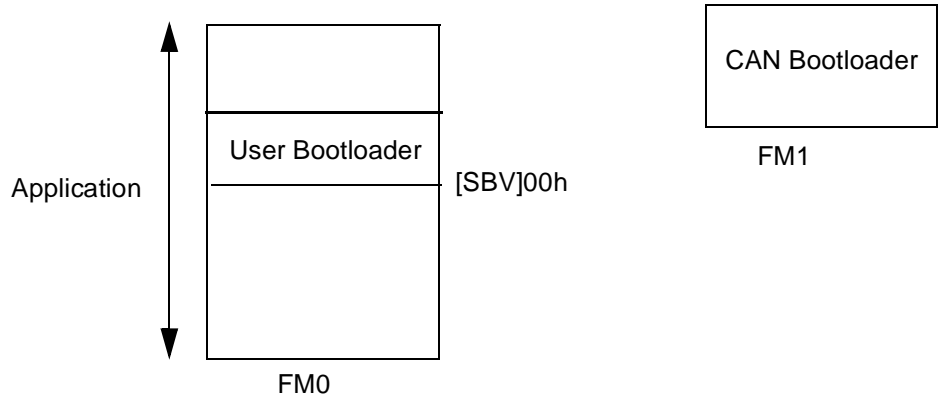

FLIP Software Program

FLIP is a PC software program running under Windows® 9x/2000/XP Windows NT® and LINUX® that supports all Atmel Flash microcontroller and CAN protocol communication media.

Several CAN dongles are supported by FLIP (for Windows).

This software program is available free of charge from the Atmel web site.

In-System Programming

ISP allows the user to program or reprogram a microcontroller's on-chip Flash memory through the CAN network without removing it from the system and without the need of a pre-programmed application.

This section describes how to start the CAN bootloader and the higher level protocols over the CAN.

Boot Process

The bootloader can be activated in two ways:

- Hardware condition
- Regular boot process

Hardware Condition

The Hardware conditions ($EA = 1$, $PSEN = 0$) during the \overline{RESET} falling edge force the on-chip bootloader execution. In this way the bootloader can be carried out whatever the user Flash memory content.

As PSEN is an output port in normal operating mode (running user application or bootloader code) after reset, it is recommended to release PSEN after falling edge of reset signal. The hardware conditions are sampled at reset signal falling edge, thus they can be released at any time when reset input is low.

Figure 3. Regular Boot Process

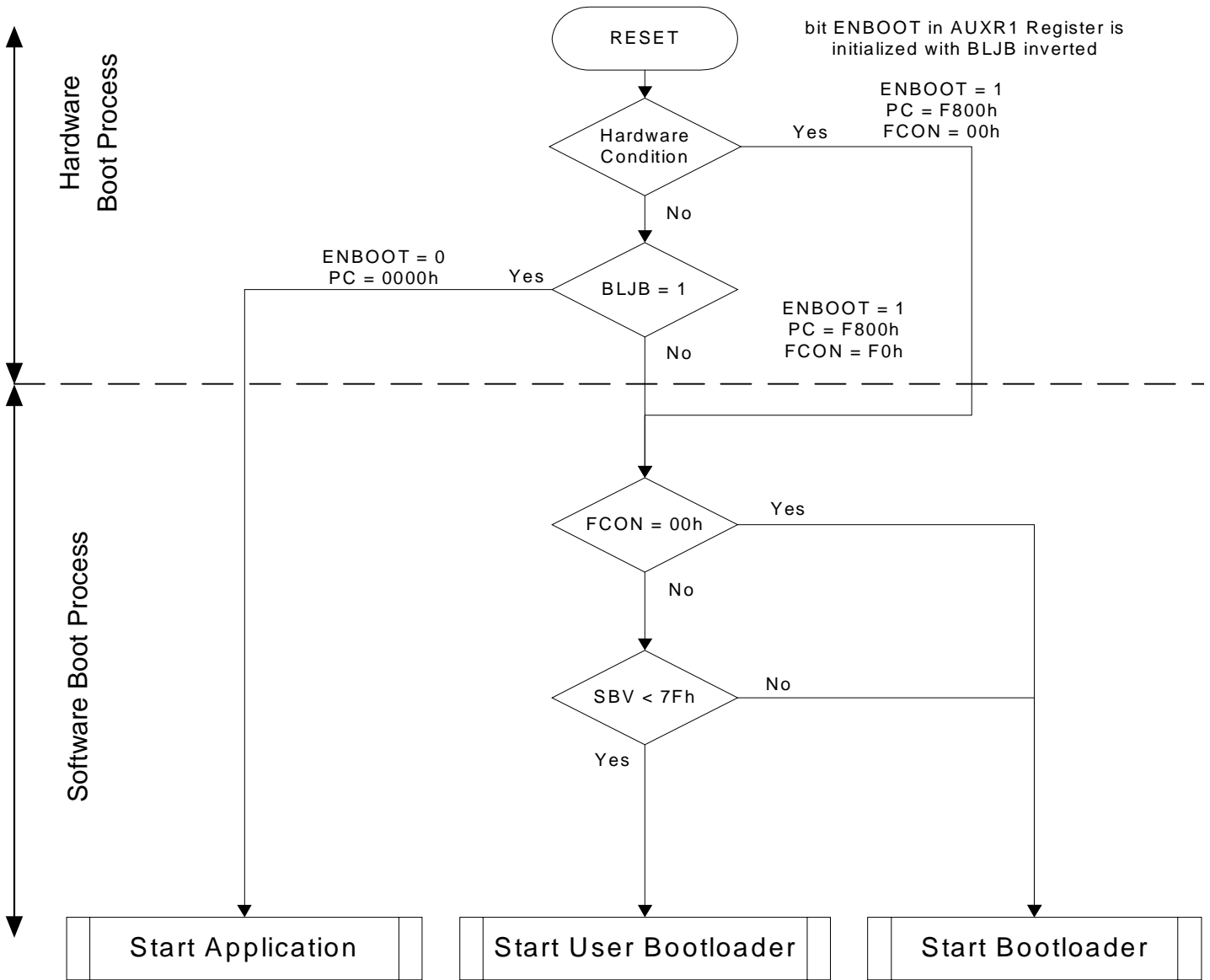

Physical Layer

The CAN is used to transmit information has the following configuration:

- Standard Frame CAN format 2.0A (identifier 11-bit)
- Frame: Data Frame
- Baud rate: autobaud is performed by the bootloader

CAN Controller Initialization

Two ways are possible to initialize the CAN controller:

- Use the software autobaud
- Use the user configuration stored in the CANBT1, CANBT2 and CANBT3

The selection between these two solutions is made with EB:

- EB = FFh: the autobaud is performed.
- EB not equal to FFh: the CANBT1:2:3 are used.

CANBT1:3 and EB can be modified by user through a set of API or with ISP commands.

The figure below describes the CAN controller flow.

Figure 4. CAN Controller Initialization

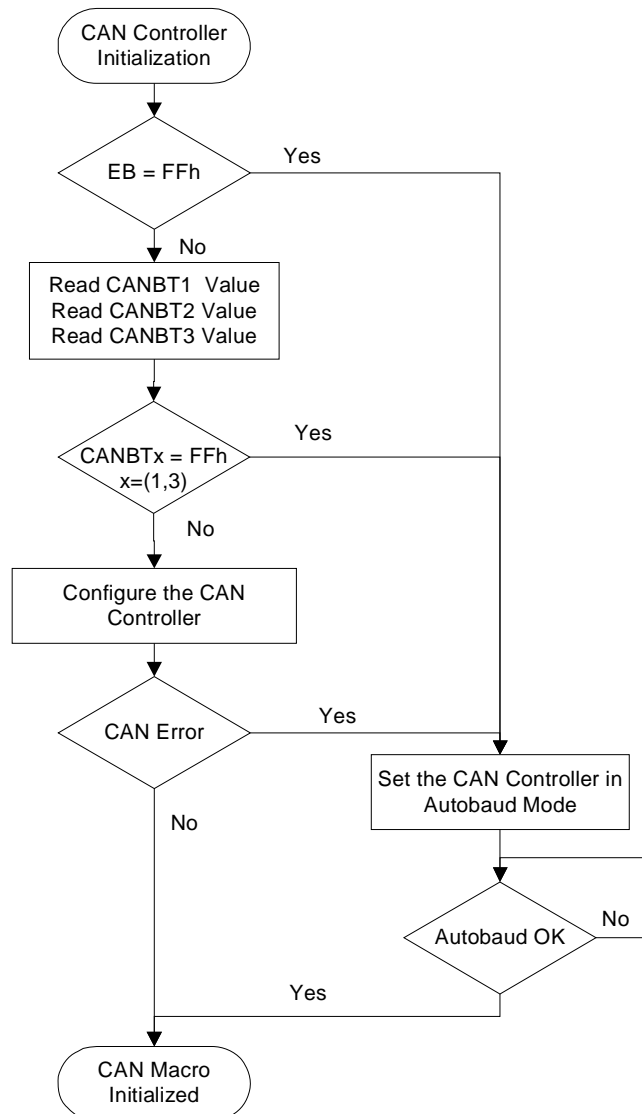

CAN Autobaud

The following table shows the auto baud performance for a point-to-point connection in X1 mode.

	8 MHz	11.059 MHz	12 MHz	16 MHz	20 MHz	22.1184 MHz	24 MHz	25 MHz	32 MHz	40 MHz
20K										
100K										
125K				–					–	
250K									–	
500K										
1M	–	–	–							

Note: '–' indicates an impossible configuration.

CAN Autobaud Limitation

The CAN Autobaud implemented in the bootloader is efficient only in point-to-point connection.

Because in a point-to-point connection, the transmit CAN message is repeated until a hardware acknowledge is done by the receiver.

The bootloader can acknowledge an incoming CAN frame only if a configuration is found.

This functionality is not guaranteed on a network with several CAN nodes.

Protocol

Generic CAN Frame Description

Identifier	Control	Data
11-bit	1 byte	8 bytes max

- Identifier: Identifies the frame (or message). Only the standard mode (11-bit) is used.
- Control: Contains the DLC information (number of data in Data field) 4-bit.
- Data: Data field consists of zero to eight bytes. The interpretation within the frame depends on the Identifier field.

The CAN Protocol manages directly using hardware a checksum and an acknowledge.

Note: To describe the ISP CAN Protocol, we use Symbolic name for Identifier, but default values are given.

Command Description

This protocol allows to:

- Initiate the communication
- Program the Flash or EEPROM Data
- Read the Flash or EEPROM Data
- Program Configuration Information
- Read Configuration and Manufacturer Information
- Erase the Flash
- Start the application

Overview of the protocol is detailed in Appendix-A.

Several CAN message identifiers are defined to manage this protocol.

Identifier	Command Effect	Value
ID_SELECT_NODE	Open/Close a communication with a node	[CRIS]0h
ID_PROG_START	Start a Flash/EEPROM programming	[CRIS]1h
ID_PROG_DATA	Data for Flash/EEPROM programming	[CRIS]2h
ID_DISPLAY_DATA	Display data	[CRIS]3h
ID_WRITE_COMMAND	Write in XAF, or Hardware Byte	[CRIS]4h
ID_READ_COMMAND	Read from XAF or Hardware Byte and special data	[CRIS]5h
ID_ERROR	Error message from bootloader only	[CRIS]6h

It is possible to allocate a new value for CAN ISP identifiers by writing the byte CRIS with the base value for the group of identifier.

The maximum value for CRIS is 7Fh and the default CRIS value is 00h.

Figure 5. Identifier Remapping

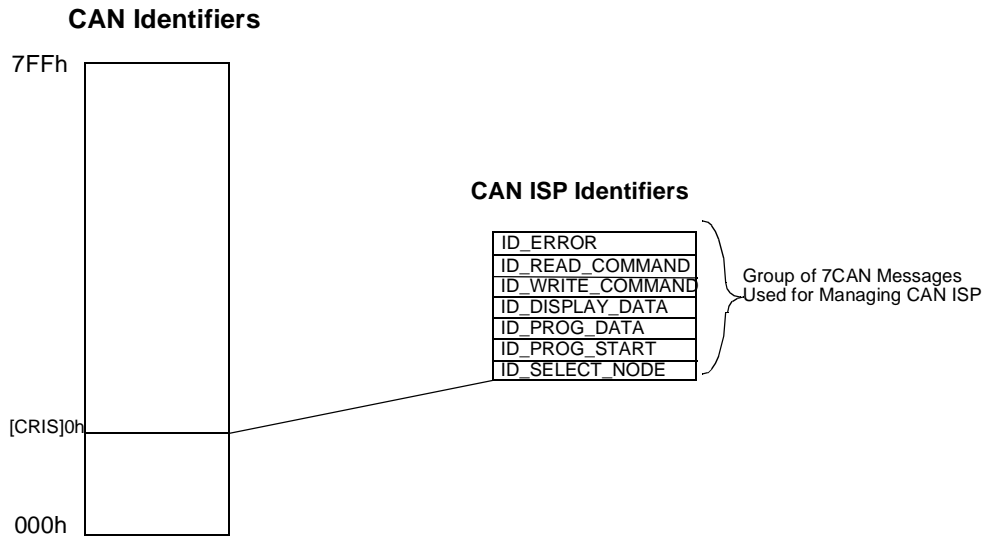

Communication Initialization

The communication with a device (CAN node) must be opened prior to initiate any ISP communication.

To open communication with the device, the Host sends a “connecting” CAN message (ID_SELECT_NODE) with the node number (NNB) passed in parameter.

If the node number passed is equal to FFh then the CAN bootloader accepts the communication (Figure 6).

Otherwise the node number passed in parameter must be equal to the local Node Number (Figure 7).

Figure 6. First Connection

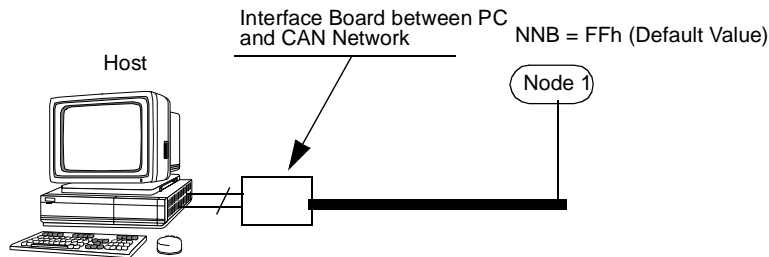
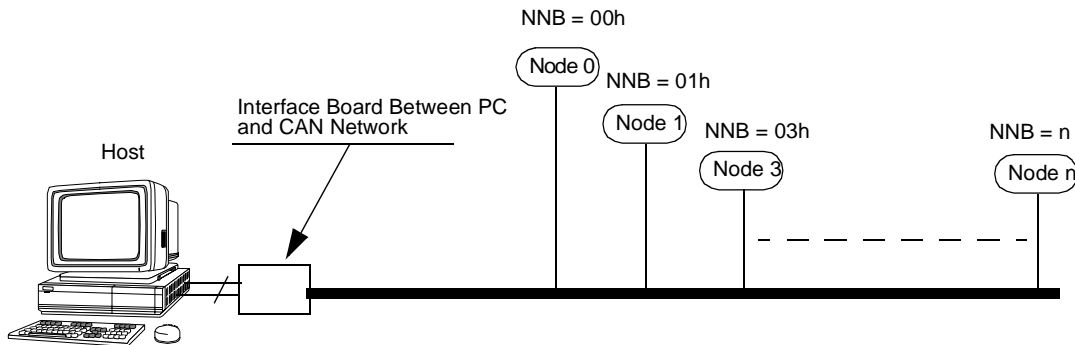

Figure 7. On Network Connection



Before opening a new communication with another device, the current device communication must be closed with its connecting CAN message (ID_SELECT_NODE).

Request From Host

Identifier	Length	Data[0]
ID_SELECT_NODE	1	num_node

Note: num_node is the NNB (Node Number Byte) to which the Host wants to talk to.

Answers From Bootloader

Identifier	Length	Data[0]	Data[1]	Comment
ID_SELECT_NODE	2	boot_version	00h	Communication close
			01h	Communication open

Note: Data[0] contains the bootloader version.

If the communication is closed then all the others messages won't be managed by bootloader.

ID_SELECT_NODE Flow Description

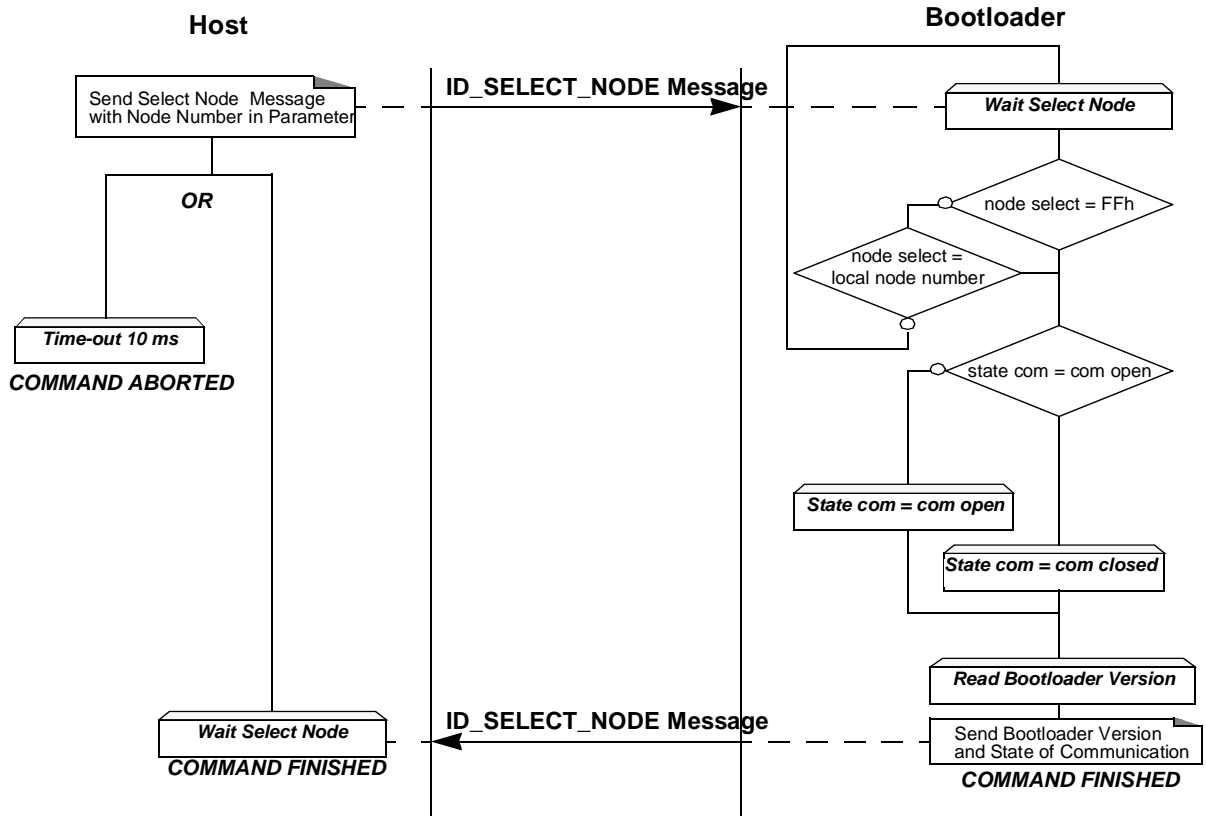

Example

	identifier	length	data
HOST	Id_select_node	01	FF
BOOTLOADER	Id_select_node	02	01 01

Programming the Flash or EEPROM Data

The ID_PROG_START flow described below shows how to program data in the Flash memory or in the EEPROM data memory. This operation can be executed only with a device previously opened in communication.

1. The first step is to indicate which memory area (Flash or EEPROM data) is selected and the range address to program.
2. The second step is to transmit the data.

The bootloader programs on a page of 128 bytes basis when it is possible.

The host must take care of the following:

- The data to program transmitted within a CAN frame are in the same page.
 - To transmit 8 data bytes in CAN message when it is possible
3. To start the programming operation, the Host sends a “start programming” CAN message (ID_PROG_START) with the area memory selected in data[0], the start address and the end address passed in parameter.

Requests from Host

Identifier	Length	Data[0]	Data[1]	Data[2]	Data[3]	Data[4]
ID_PROG_START	5	00h	address_start		address_end	
		01h				

- Notes:
1. Data[0] chooses the area to program:
 - 00h: Flash
 - 01h: EEPROM data
 2. Address_start gives the start address of the programming command.
 3. Address_end gives the last address of the programming command.

Answers from Bootloader

The device has two possible answers:

- If the chip is protected from program access an “Error” CAN message is sent (see Section “Error Message Description”, page 22).
- Otherwise an acknowledge is sent.

Identifier	Length
ID_PROG_START	0

The second step of the programming operation is to send data to program.

Request from Host

To send data to program, the Host sends a ‘programming data’ CAN message (ID_PROG_DATA) with up to 8 data by message and must wait for the answer of the device before sending the next data to program.

Identifier	Length	Data[0]	...	Data[7]
ID_PROG_DATA	up to 8	x	...	x

Answers from Bootloader

The device has two possible answers:

- If the device is ready to receive new data, it sends a “programming data” CAN message (ID_PROG_DATA) with the result Command_new passed in parameter.
- If the device has finished the programming, it sends a “programming data” CAN message (ID_PROG_DATA) with the result Command_ok passed in parameter.

Identifier	Length	Data[0]	Description
ID_PROG_DATA	1	00h	Command OK
		01h	Command fail
		02h	Command new data

ID_PROG_DATA Flow Description

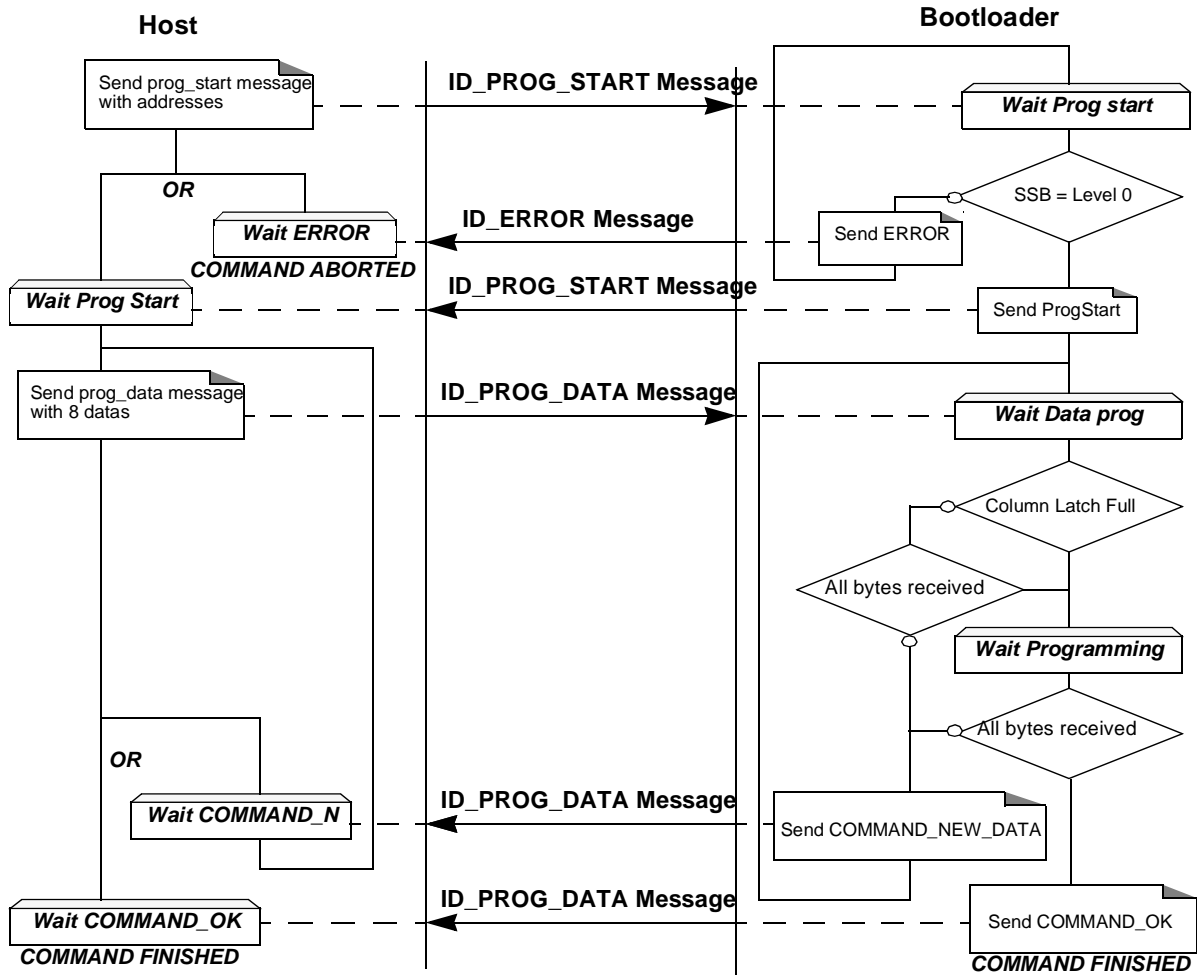

Example

Programming Data (write 55h from 0000h to 0008h in the flash)

	identifier	control	data				
HOST	Id_prog_start	05	00	00	00	00	08
BOOTLOADER	Id_prog_start	00					
HOST	Id_prog_data	08	55	55	55	55	55
BOOTLOADER	Id_prog_data	01	02	// command_new_data			
HOST	Id_prog_data	01	55				
BOOTLOADER	Id_prog_data	01	00	// command_ok			

Programming Data (write 55h from 0000h to 0008h in the flash)with SSB in write security

	identifier	control	data				
HOST	Id_prog_start	04	00	00	00	08	
BOOTLOADER	Id_error	01	00	// error_security			

Reading the Flash or EEPROM Data

The ID_DISPLAY_DATA flow described below allows the user to read data in the Flash memory or in the EEPROM data memory. A blank check command on the Flash memory is possible with this flow.

This operation can be executed only with a device previously opened in communication.

To start the reading operation, the Host sends a “Display Data” CAN message (Id_display_data) with the area memory selected, the start address and the end address passed in parameter.

The device splits into block of 8 bytes data to transfer to the Host if the number of data to display is greater than 8 data bytes.

Requests from Host

Identifier	Length	Data[0]	Data[1]	Data[2]	Data[3]	Data[4]
ID_DISPLAY_DATA	5	00h	address_start		address_end	
		01h				
		02h				

- Notes:
- Data[0] selects the area to read and the operation
 - 00h: Display Flash
 - 01h: Blank Check on the Flash
 - 02h: Display EEPROM data
 - The Address_start gives the start address to read.
 - The Address_end gives the last address to read.

Answers from Bootloader

The device has two possible answers:

- If the chip is protected from read access an “Error” CAN message is sent (see Section “Error Message Description”, page 22).
- Otherwise:
for a display command the device starts to send the data up to 8 by frame to the host. For a blank check command, the device sends a result OK or the first address not erased.

Answer to a read command:

Identifier	Length	Data[n]
ID_DISPLAY_DATA	n	x

Answer to a blank check command:

Identifier	Length	Data[0]	Data[1]	Description
ID_DISPLAY_DATA	0	-	-	Blank Check OK
	2	Address_start		

Flow Description

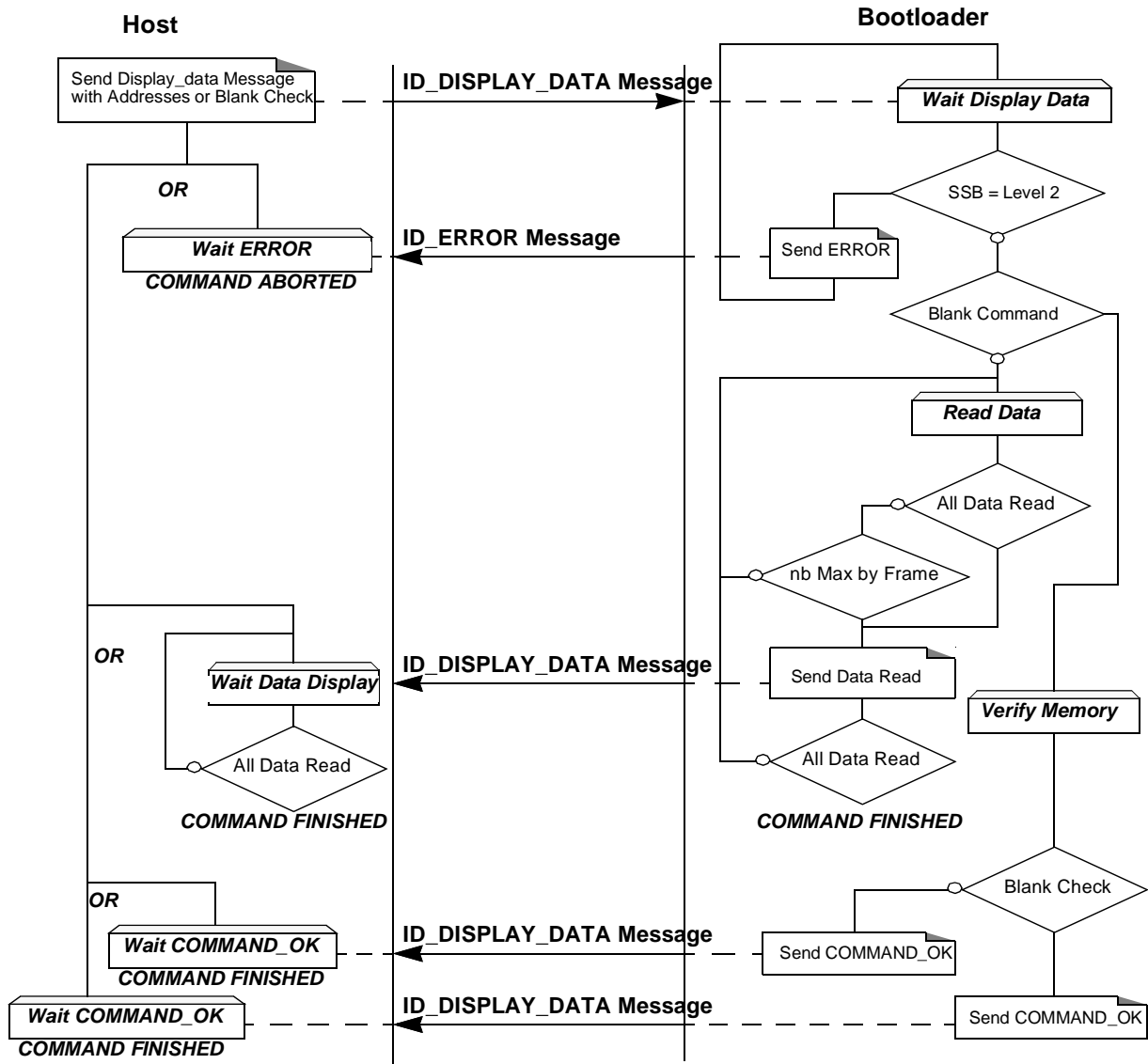

ID_DISPLAY_DATA Example

Display Data (from 0000h to 0008h)

	identifier	control	data			
HOST	Id_display_data	05	00	00	00	00 08
BOOTLOADER	Id_display_data	08	55	55	55	55 55 55 55
BOOTLOADER	Id_display_data	01	55			

Blank Check

	identifier	control	data			
HOST	Id_display_data	05	01	00	00	00 08
BOOTLOADER	Id_display_data	00	// Command ok			

Programming Configuration Information

The ID_WRITE_COMMAND flow described below allows the user to program Configuration Information regarding the bootloader functionality.

This operation can be executed only with a device previously opened in communication.

The Configuration Information can be divided in two groups:

- Boot Process Configuration:
 - BSB
 - SBV
 - Fuse bits (BLJB and X2 bits) (see Section “Mapping and Default Value of Hardware Security Byte”, page 4)
- CAN Protocol Configuration:
 - BTC_1, BTC_2, BTC_3
 - SSB
 - EB
 - NNB
 - CRIS

Note: The CAN protocol configuration bytes are taken into account only after the next reset.

To start the programming operation, the Host sends a “write” CAN message (ID_WRITE_COMMAND) with the area selected, the value passed in parameter.

Take care that the Program Fuse bit command programs the 4 Fuse bits at the same time.

Requests from Host

Identifier	Length	Data[0]	Data[1]	Data[2]	Description
ID_WRITE_COMMAND	3	01h	00h	value	write value in BSB
			01h		write value in SBV
			05h		write value in SSB
			06h		write value in EB
			1Ch		write value in BTC_1
			1Dh		write value in BTC_2
			1Eh		write value in BTC_3
			1Fh		write value in NNB
			20h		write value in CRIS
3	02h	00h	value	write value in Fuse bits	

Answers from Bootloader

The device has two possible answers:

- If the chip is protected from program access an “Error” CAN message is sent (see Section “Error Message Description”, page 22).
- Otherwise an acknowledge “Command OK” is sent.

Identifier	Length	Data[0]	Description
ID_WRITE_COMMAND	1	00h	Command OK

ID_WRITE_COMMAND Flow Description

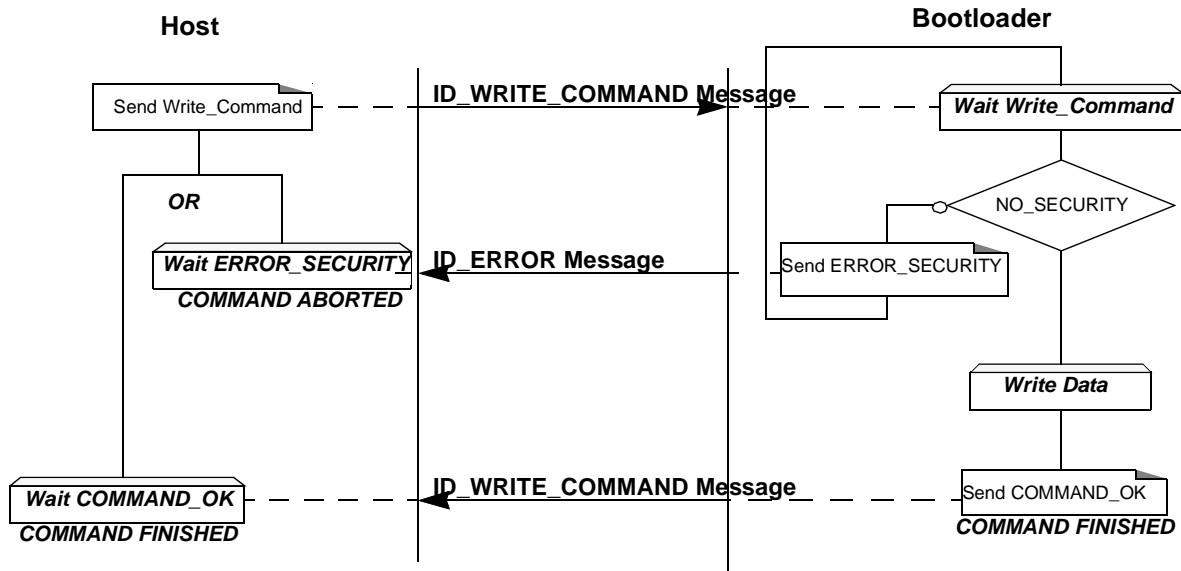

Example

Write BSB at 88h

	identifier	control	data
HOST	Id_write_command	03	01 00 88
BOOTLOADER	Id_write_command	01	00 // command_ok

Write Fuse bit at Fxh

	identifier	control	data
HOST	Id_write_command	02	02 F0
BOOTLOADER	Id_write_command	01	00 // command_ok

Reading Configuration Information or Manufacturer Information

The ID_READ_COMMAND flow described below allows the user to read the configuration or manufacturer information. This operation can be executed only with a device previously opened in communication.

To start the reading operation, the Host sends a “Read Command” CAN message (ID_READ_COMMAND) with the information selected passed in data field.

Requests from Host

Identifier	Length	Data[0]	Data[1]	Description
ID_READ_COMMAND	2	00h	00h	Read Bootloader version
			01h	Read Device ID1
			02h	Read Device ID2
	2	01h	00h	Read BSB
			01h	Read SBV
			05h	Read SSB
			06h	Read EB
			1Ch	Read BTC_1
			1Dh	Read BTC_2
			1Eh	Read BTC_3
			1Fh	Read NNB
			20h	Read CRIS
			30h	Read Manufacturer Code
			31h	Read Family Code
			60h	Read Product Name
61h	Read Product Revision			
2	02h	00h	Read HSB (Fuse bits)	

Answers from Bootloader

The device has two possible answers:

- If the chip is protected from read access an “Error” CAN message is sent (see Section “Error Message Description”).
- Otherwise:
the device answers with a Read Answer CAN message (ID_READ_COMMAND).

Identifier	Length	Data[n]
ID_READ_COMMAND	1	value

Flow Description

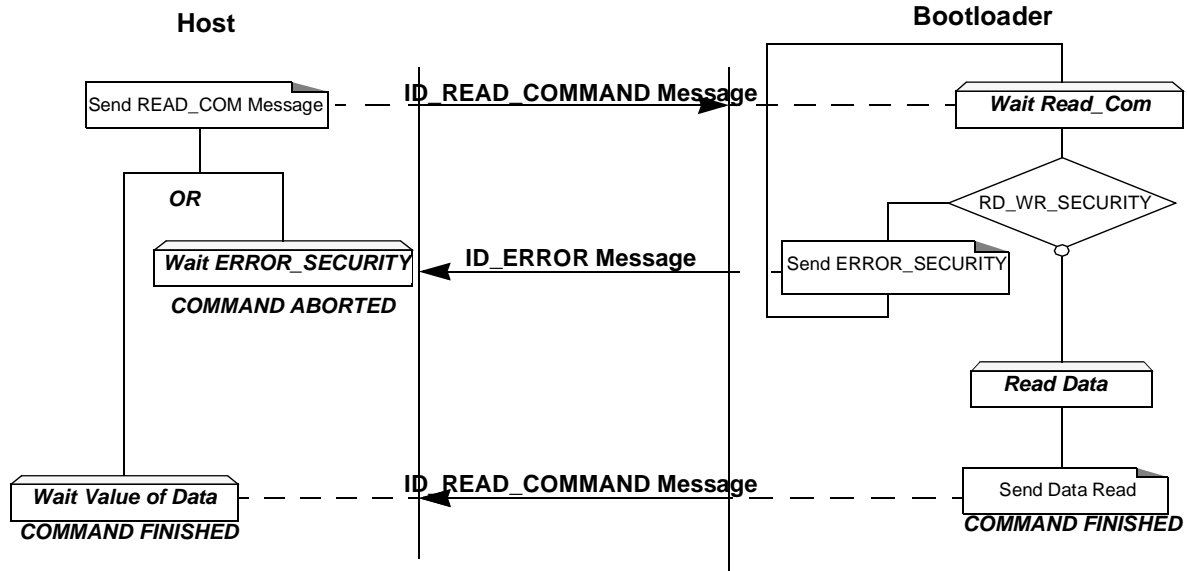

Example

Read Bootloader Version

```

          identifier  control  data
HOST      Id_read_command  02  00 00
BOOTLOADER Id_read_command  01  55 // Bootloader version 55h
  
```

Read SBV

```

          identifier  control  data
HOST      Id_read_command  02  01 01
BOOTLOADER Id_read_command  01  F5 // SBV = F5h
  
```

Read Fuse bit

```

          identifier  control  data
HOST      Id_read_command  01  02
BOOTLOADER Id_read_command  01  F0 // Fuse bit = F0h
  
```

Erasing the Flash

The ID_WRITE_COMMAND flow described below allows the user to erase the Flash memory.

This operation can be executed only with a device previously opened in communication.

Two modes of Flash erasing are possible:

- Full Chip erase
- Block erase

The Full Chip erase command erases the whole Flash (32 Kbytes) and sets some Configuration Bytes to their default values:

- BSB = FFh
- SBV = FFh
- SSB = FFh (NO_SECURITY)

The Block erase command erases only a part of the Flash.

Three Blocks are defined in the T89C51CC01:

- block0 (from 0000h to 1FFFh)
- block1 (from 2000h to 3FFFh)
- block2 (from 4000h to 7FFFh)

To start the erasing operation, the Host sends a “write” CAN message (ID_WRITE_COMMAND).

Requests from Host

Identifier	Length	Data[0]	Data[1]	Description
ID_WRITE_COMMAND	2	00h	00h	Erase block0 (0K to 8K)
			20h	Erase block1 (8K to 16K)
			40h	Erase block2 (16K to 32K)
			FFh	Full chip erase

Answers from Bootloader

As the Program Configuration Information flows, the erase block command has two possible answers:

- If the chip is protected from program access an “Error” CAN message is sent (see Section “Error Message Description”, page 22).
- Otherwise an acknowledge is sent.

The full chip erase is always executed whatever the Software Security Byte value is.

On a full chip erase command an acknowledge “Command OK” is sent.

Identifier	Length	Data[0]	Description
ID_WRITE_COMMAND	1	00h	Command OK

Example

Full Chip Erase

	identifier	control	data
HOST	Id_write_command	02	00 FF
BOOTLOADER	Id_write_command	01	00 // command_ok

Starting the Application

The ID_WRITE_COMMAND flow described below allows to start the application directly from the bootloader upon a specific command reception.

This operation can be executed only with a device previously opened in communication.

Two options are possible:

- Start the application with a reset pulse generation (using watchdog).
When the device receives this command, the watchdog is enabled and the bootloader enters a waiting loop until the watchdog resets the device.
Take care that if an external reset chip is used, the reset pulse in output may be wrong and in this case the reset sequence is not correctly executed.
- Start the application without reset
A jump at the address 0000h is used to start the application without reset.

To start the application, the Host sends a “Start Application” CAN message (ID_WRITE_COMMAND) with the corresponding option passed in parameter.

Requests from Host

Identifier	Length	Data[0]	Data[1]	Data[2]	Data[3]	Description
ID_WRITE_COMMAND	2	03h	00h	-	-	Start Application with a reset pulse generation
	4		01h	address		Start Application with a jump at “address”

Answer from Bootloader

No answer is returned by the device.

Example

Start application

	identifier	control	data
HOST	Id_write_command	04	03 01 00 00
BOOTLOADER	No answer		

Error Message Description

The error message is implemented to report when an action required is not possible.

- At the moment only the security error is implemented and only the device can answer this kind of CAN message (ID_ERROR).

Identifier	Length	Data[0]	Description
ID_ERROR	1	00h	Software Security Error

In-Application Programming/Self-programming

The IAP allows to reprogram a microcontroller on-chip Flash memory without removing it from the system and while the embedded application is running.

The user application can call Application Programming Interface (API) routines allowing IAP. These API are executed by the bootloader.

To call the corresponding API, the user must use a set of Flash_api routines which can be linked with the application.

Example of Flash_api routines are available on the Atmel web site on the software application note:

C Flash Drivers for the T89C51CC01CA for Keil Compilers

The Flash_api routines on the package work only with the CAN bootloader.

The Flash_api routines are listed in Appendix-B.

API Call

Process

The application selects an API by setting the 4 variables available when the Flash_api library is linked to the application.

These four variables are located in RAM at fixed address:

- api_command: 1Ch
- api_value: 1Dh
- api_dph: 1Eh
- api_dpl: 1Fh

All calls are made through a common interface "USER_CALL" at the address FFC0h.

The jump at the USER_CALL must be done by LCALL instruction to be able to come-back in the application.

Before jump at the USER_CALL, the bit ENBOOT in AUXR1 register must be set.

Constraints

The interrupts are not disabled by the bootloader.

Interrupts must be disabled by user prior to jump to the USER_CALL, then re-enabled when returning.

Interrupts must also be disabled before accessing EEPROM data then re-enabled after.

The user must take care of hardware watchdog before launching a Flash operation.

For more information regarding the Flash writing time see the T89C51CC01 datasheet.



API Commands

Several types of APIs are available:

- Read/Program Flash and EEPROM data Memory
- Read Configuration and Manufacturer Information
- Program Configuration Information
- Erase Flash
- Start bootloader

Read/Program Flash and EEPROM Data Memory

All routines to access EEPROM data are managed directly from the application without using bootloader resources.

The bootloader is not used to read the Flash memory.

For more details on these routines see the T89C51CC01 datasheet sections “Program/Code Memory” and “EEPROM Data Memory”

Two routines are available to program the Flash:

- __api_wr_code_byte
- __api_wr_code_page

- The application program loads the column latches of the Flash then calls the __api_wr_code_byte or __api_wr_code_page see datasheet in section “Program/Code Memory”.
- Parameter Settings

API Name	api_command	api_dph	api_dpl	api_value
__api_wr_code_byte __api_wr_code_page	0Dh	-	-	-

- Instruction: LCALL FFC0h.

Note: No special resources are used by the bootloader during this operation.

Read Configuration and Manufacturer Information

- Parameter Settings

API Name	api_command	api_dph	api_dpl	api_value
__api_rd_HSB	08h	-	00h	return HSB
__api_rd_BSB	05h	-	00h	return BSB
__api_rd_SBV	05h	-	01h	return SBV
__api_rd_SSB	05h	-	05h	return SSB
__api_rd_EB	05h	-	06h	return EB
__api_rd_CANBTC1	05h	-	1Ch	return CANBTC1
__api_rd_CANBTC2	05h	-	1Dh	return CANBTC2
__api_rd_CANBTC3	05h	-	1Eh	return CANBTC3
__api_rd_NNB	05h	-	1Fh	return NNB
__api_rd_CRIS	05h	-	20h	return CRIS
__api_rd_manufacturer	05h	-	30h	return manufacturer id
__api_rd_device_id1	05h	-	31h	return id1

API Name	api_command	api_dph	api_dpl	api_value
__api_rd_device_id2	05h	-	60h	return id2
__api_rd_device_id3	05h	-	61h	return id3
__api_rd_bootloader_version	0Eh	-	00h	return value

- Instruction: LCALL FFC0h.
- At the complete API execution by the bootloader, the value to read is in the api_value variable.

Note: No special resources are used by the bootloader during this operation.

Program Configuration Information

- Parameter Settings

API Name	api_command	api_dph	api_dpl	api_value
__api_clr_BLJB	07h	-	-	(HSB & BFh) 40h
__api_set_BLJB	07h	-	-	HSB & BFh
__api_clr_X2	07h	-	-	(HSB & 7Fh) 80h
__api_set_X2	07h	-	-	HSB & 7Fh
__api_wr_BSB	04h	-	00h	value to write
__api_wr_SBV	04h	-	01h	value to write
__api_wr_SSB	04h	-	05h	value to write
__api_wr_EB	04h	-	06h	value to write
__api_wr_CANBTC1	04h	-	1Ch	value to write
__api_wr_CANBTC2	04h	-	1Dh	value to write
__api_wr_CANBTC3	04h	-	1Eh	value to write
__api_wr_NNB	04h	-	1Fh	value to write
__api_wr_CRIS	04h	-	20h	value to write

- Instruction: LCALL FFC0h.

Note: 1. See in the T89C51CC01 datasheet the time required for a write operation.
2. No special resources are used by the bootloader during these operations.

Erasing the Flash

The T89C51CC01 Flash memory is divided in three blocks of 8K Bytes:

Block 0: from address 0000h to 1FFFh

Block 1: from address 2000h to 3FFFh

Block 2: from address 4000h to 7FFFh

These three blocks contain 128 pages.

- Parameter Settings

API Name	api_command	api_dph	api_dpl	api_value
__api_erase_block0	00h	00h	-	-

API Name	api_command	api_dph	api_dpl	api_value
__api_erase_block1	00h	20h	-	
__api_erase_block2	00h	40h	-	

- Instruction: LCALL FFC0h.

- Note:
1. See the T89C51CC01 datasheet for the time required for a write operation and this time must be multiplied by the number of pages.
 2. No special resources are used by the bootloader during these operations.

Starting the Bootloader

There are two start bootloader routines possible:

1. This routine allows to start at the beginning of the bootloader or after a reset. After calling this routine the regular boot process is performed and the communication must be opened before any action.
 - No special parameter setting
 - Set bit ENBOOT in AUXR1 register
 - Instruction: LJUMP or LCALL at address F800h
2. This routine allows to start the bootloader with the CAN bit configuration of the application and start with the state "communication open". That means the bootloader will return the message "ID_SELECT_NODE" with the field com port open.
 - No special parameter setting
 - Set bit ENBOOT in AUXR1 register
 - Instruction: LJUMP or LCALL at address FF00h

Appendix-A

Table 1. Summary of Frames from Host

Identifier	Length	Data[0]	Data[1]	Data[2]	Data[3]	Data[4]	Description	
Id_select_node (CRIS:0h)	1	num node	-	-	-	-	Open/Close communication	
Id_prog_start (CRIS:1h)	5	00h	start_address		end_address		Init Flash programming	
		01h					Init EEPROM programming	
Id_prog_data (CRIS:2h)	n	data[0:8]					Data to program	
Id_display_data (CRIS:3h)	5	00h	start_address		end_address		Display Flash Data	
		01h					Blank Check in Flash	
		02h					Display EEPROM Data	
Id_write_command (CRIS:4h)	2	00h	00h	-	-	-	Erase block0 (0K to 8K)	
			20h	-	-	-	Erase block1 (8K to 16K)	
			40h	-	-	-	Erase block2 (16K to 32K)	
			FFh	-	-	-	Full-chip Erase	
	3	01h	value	00h	-	-	-	Write value in BSB
				01h	-	-	-	Write value in SBV
				05h	-	-	-	Write value in SSB
				06h	-	-	-	Write value in EB
				1Ch	-	-	-	Write BTC_1
				1Dh	-	-	-	Write BTC_2
				1Eh	-	-	-	Write BTC_3
				1Fh	-	-	-	Write NNB
	20h	-	-	-	Write CRIS			
	3	02h	00h	value	-	-	Write value in Fuse (HSB)	
	2	03h	00h	-	-	-	Start Application with Hardware Reset	
4	01h		address		-	Start Application by L JMP address		

Table 1. Summary of Frames from Host (Continued)

Identifier	Length	Data[0]	Data[1]	Data[2]	Data[3]	Data[4]	Description
Id_read_command (CRIS:5h)	2	00h	00h	-	-	-	Read Bootloader Version
			01h	-	-	-	Read Device ID1
			02h	-	-	-	Read Device ID2
	2	01h	00h	-	-	-	Read BSB
			01h	-	-	-	Read SBV
			05h	-	-	-	Read SSB
			06h	-	-	-	Read EB
			30h	-	-	-	Read Manufacturer Code
			31h	-	-	-	Read Family Code
			60h	-	-	-	Read Product Name
			61h	-	-	-	Read Product Revision
			1Ch	-	-	-	Read BTC_1
			1Dh	-	-	-	Read BTC_2
			1Eh	-	-	-	Read BTC_3
			1Fh	-	-	-	Read NNB
			20h	-	-	-	Read CRIS
			2	02h	00h	-	-

Table 2. Summary of Frames from Target (Bootloader)

Identifier	Length	Data[0]	Data[1]	Data[2]	Data[3]	Data[4]	Description
Id_select_node (CRIS:0h)	2	Boot version	00h	-	-	-	communication close
			01h	-	-	-	communication open
Id_prog_start (CIRS:1h)	0	-	-	-	-	-	Command OK
Id_prog_data (CRIS:2h)	1	00h	-	-	-	-	Command OK
		01h	-	-	-	-	Command fail
		02h	-	-	-	-	Command New Data
Id_display_data (CRIS:3h)	n	n data (n = 0 to 8)					Data read
	0	-	-	-	-	-	Blank Check OK
	2	first address not blank		-	-	-	Blank Check fail
Id_write_command (CIRS:4h)	1	00h	-	-	-	-	Command OK
Id_read_command (CRIS:5h)	1	Value	-	-	-	-	Read Value

Table 2. Summary of Frames from Target (Bootloader) (Continued)

Identifier	Length	Data[0]	Data[1]	Data[2]	Data[3]	Data[4]	Description
Id_error (CRIS:6h)	1	00h	-	-	-	-	Software Security Error

Appendix-B

Table 3. API Summary

Function Name	Bootloader Execution	api_command	api_dph	api_dpl	api_value
__api_rd_code_byte	no				
__api_wr_code_byte	yes	0Dh	-	-	-
__api_wr_code_page	yes	0Dh	-	-	-
__api_erase_block0	yes	00h	00h	-	-
__api_erase_block1	yes	00h	20h	-	-
__api_erase_block2	yes	00h	40h	-	-
__api_rd_HSB	yes	08h	-	00h	return value
__api_clr_BLJB	yes	07h	-	-	(HSB & BFh) 40h
__api_set_BLJB	yes	07h	-	-	HSB & BFh
__api_clr_X2	yes	07h	-	-	(HSB & 7Fh) 80h
__api_set_X2	yes	07h	-	-	HSB & 7Fh
__api_rd_BSB	yes	05h	-	00h	return value
__api_wr_BSB	yes	04h	-	00h	value
__api_rd_SBV	yes	05h	-	01h	return value
__api_wr_SBV	yes	04h	-	01h	value
__api_erase_SBV	yes	04h	-	01h	FFh
__api_rd_SSB	yes	05h	-	05h	return value
__api_wr_SSB	yes	04h	-	05h	value
__api_rd_EB	yes	05h	-	06h	return value
__api_wr_EB	yes	04h	-	06h	value
__api_rd_CANBTC1	yes	05h	-	1Ch	return value
__api_wr_CANBTC1	yes	04h	-	1Ch	value
__api_rd_CANBTC2	yes	05h	-	1Dh	return value
__api_wr_CANBTC2	yes	04h	-	1Dh	value
__api_rd_CANBTC3	yes	05h	-	1Eh	return value
__api_wr_CANBTC3	yes	04h	-	1Eh	value
__api_rd_NNB	yes	05h	-	1Fh	return value
__api_wr_NNB	yes	04h	-	1Fh	value
__api_rd_CRIS	yes	05h	-	20h	return value
__api_wr_CRIS	yes	04h	-	20h	value
__api_rd_manufacturer	yes	05h	-	30h	return value
__api_rd_device_id1	yes	05h	-	31h	return value

Table 3. API Summary (Continued)

Function Name	Bootloader Execution	api_command	api_dph	api_dpl	api_value
__api_rd_device_id2	yes	05h	-	60h	return value
__api_rd_device_id3	yes	05h	-	61h	return value
__api_rd_bootloader_version	yes	0Eh	-	00h	return value
__api_eeprom_busy	no	-	-	-	-
__api_rd_eeprom_byte	no	-	-	-	-
__api_wr_eeprom_byte	no	-	-	-	-
__api_start_bootloader	no	-	-	-	-
__api_start_isp	no	-	-	-	-

Document Revision History

Changes from 4210C - 12/03 to 4210D - 05/06

1. Changes to full chip erase command.



Atmel Headquarters

Corporate Headquarters

2325 Orchard Parkway
San Jose, CA 95131
TEL 1(408) 441-0311
FAX 1(408) 487-2600

Europe

Atmel Sarl
Route des Arsenaux 41
Case Postale 80
CH-1705 Fribourg
Switzerland
TEL (41) 26-426-5555
FAX (41) 26-426-5500

Asia

Room 1219
Chinachem Golden Plaza
77 Mody Road Tsimhatsui
East Kowloon
Hong Kong
TEL (852) 2721-9778
FAX (852) 2722-1369

Japan

9F, Tonetsu Shinkawa Bldg.
1-24-8 Shinkawa
Chuo-ku, Tokyo 104-0033
Japan
TEL (81) 3-3523-3551
FAX (81) 3-3523-7581

Atmel Operations

Memory

2325 Orchard Parkway
San Jose, CA 95131
TEL 1(408) 441-0311
FAX 1(408) 436-4314

Microcontrollers

2325 Orchard Parkway
San Jose, CA 95131
TEL 1(408) 441-0311
FAX 1(408) 436-4314

La Chantrerie
BP 70602
44306 Nantes Cedex 3, France
TEL (33) 2-40-18-18-18
FAX (33) 2-40-18-19-60

ASIC/ASSP/Smart Cards

Zone Industrielle
13106 Rousset Cedex, France
TEL (33) 4-42-53-60-00
FAX (33) 4-42-53-60-01

1150 East Cheyenne Mtn. Blvd.
Colorado Springs, CO 80906
TEL 1(719) 576-3300
FAX 1(719) 540-1759

Scottish Enterprise Technology Park
Maxwell Building
East Kilbride G75 0QR, Scotland
TEL (44) 1355-803-000
FAX (44) 1355-242-743

RF/Automotive

Theresienstrasse 2
Postfach 3535
74025 Heilbronn, Germany
TEL (49) 71-31-67-0
FAX (49) 71-31-67-2340

1150 East Cheyenne Mtn. Blvd.
Colorado Springs, CO 80906
TEL 1(719) 576-3300
FAX 1(719) 540-1759

Biometrics/Imaging/Hi-Rel MPU/ High Speed Converters/RF Data- com

Avenue de Rochepleine
BP 123
38521 Saint-Egreve Cedex, France
TEL (33) 4-76-58-30-00
FAX (33) 4-76-58-34-80

e-mail

literature@atmel.com

Web Site

<http://www.atmel.com>

© Atmel Corporation 2003.

Atmel Corporation makes no warranty for the use of its products, other than those expressly contained in the Company's standard warranty which is detailed in Atmel's Terms and Conditions located on the Company's web site. The Company assumes no responsibility for any errors which may appear in this document, reserves the right to change devices or specifications detailed herein at any time without notice, and does not make any commitment to update the information contained herein. No licenses to patents or other intellectual property of Atmel are granted by the Company in connection with the sale of Atmel products, expressly or by implication. Atmel's products are not authorized for use as critical components in life support devices or systems.

Atmel Corporation 2003. All rights reserved. Atmel, the Atmel logo, and combinations thereof are registered trademarks of Atmel Corporation or its subsidiaries. Other terms and product names in this document may be the trademarks of others. Windows® is a registered trademark of Microsoft Corporation. Linux® is a registered trademark of Linus Torvalds.



Printed on recycled paper.